

MARINA COMMITTEE MEETING

DATE OF MEETING: March 7, 2022, at 5:00 p.m. DeWitt County Building

MEMBERS PRESENT: Dan Matthews – Chair, Terry Ferguson, Travis Houser, and Aaron Kammeyer. Also, present, Dee Dee Rentmeister, County Administrator, Joe and Marybeth Caldwell- marina operators.

MEMBERS ABSENT: Jay Wickenhauser

SUMMARY OF DISCUSSION:

- Dick Hansen from the Sailing Association was present to discuss with the committee an addition to their dock along with a floating section. Mr. Hansen has completed the permit with the Army Corp of Engineers and needs the County to sign the application. He has also applied to IEPA and IDNR for approval of the extension. The Sailboat Association will be doing the addition themselves. Committee members had no issues with the planned addition.
- Matthews asked Mr. Hansen if the Sailboat Association would put together a plan of what they would like to continue to do with the leased five acres so that it could be reviewed when looking at an upcoming lease.
- Motion by Kammeyer, 2nd by Houser to approve last month's minutes. Voice vote, motion carried.
- Motion by Ferguson, 2nd by Houser to approve the claims. Voice vote, motion carried.
- Matthews presented a quote from JLS to provide barge work for dock 7 – one day of work – in the amount of \$5000.00. Motion by Kammeyer, 2nd by Ferguson to approve the quote from JLS to provide barge work for dock 7 in the amount of \$5000.00. Voice vote, motion carried.
- Discussion on purchasing additional floats. Joe indicated that he will not have an estimate of the number of floats needed until JLS comes out. Motion by Kammeyer, 2nd by Ferguson to approve up to \$5000 for floats. Voice vote, motion carried.
- Committee reviewed the purchase contract for the floating breakwater system. An initial payment in the amount of \$92,668.50 is due with the signed contract. Will have the state's attorney review the purchase contract.
- Discussion on breakwater options for the gas dock. Would like to consider the concrete type of breakwater. Will bid this portion out when ready.
- Review quote from Atchison Electric to install motion detectors in the restrooms by the ramp in the amount of \$995.30. Motion by Kammeyer, 2nd by Houser to approve the quote from Atchison Electric in the amount of \$995.30 to install motion detectors in the restrooms by the ramp. Voice vote, motion carried.
- Joe discussed with the committee the following items:
 - The wooden breakwater came apart today. Will attempt to go out and connect the pieces together.
 - There two big piles of wood and brush that needs burned. Committee told Joe to ahead and burn.
 - Two of the abandoned boats have been removed. What to do with the rest?
- Dee Dee informed the committee that she received a call from Leslie Roberts inquiring where she was at on the waiting list. She has been on the list since 2020 and hasn't been contacted. Joe and Marybeth indicated that she was on the list last year but there are others ahead of her. Dee Dee asked for a current list. Marybeth indicated that they had a current list that they could send.
- General discussion about lifts and ones that aren't working and damaging the slips.
- Joe will notify those with jet skis where these will be placed this coming season to ensure that the renters are ok with the placement. If they are not ok with the placement, then the jet ski won't be kept at the marina.
- Houser indicated that the parking signage has been ordered.
- Ferguson stated that the two estimates that he received concerning the removal of the islands in the parking came in above \$30,000. This project will need to be bid out.
- Discussion on what the committee would like to have on a new management lease. Briefly discussed different ideas to manage the marina, restaurant, mechanic, etc. Committee members will put together a

list of items that they feel need to be addressed in a contract.

- Discussion on the sale of the 75 acres. Ferguson indicated that advertisement has begun. Another local auctioneer has contacted members of the board inquiring why he wasn't given a chance to auction the property.
- Motion by Kammeyer, 2nd by Houser to adjourn at 6:43 p.m. Voice vote, motion carried.

COMMITTEE ACTION:

Approve last month's minutes.

Approve the claims.

Approve the quote from JLS to provide barge work for dock 7 in the amount of \$5000.00.

Approve up to \$5000 for floats.

Approve the quote from Atchison Electric in the amount of \$995.30 to install motion detectors in the restrooms by the ramp.

RECOMMENDATIONS TO THE BOARD:

None

DATE OF NEXT MEETING: March 7, 2022, at 5:00 p.m. County Building

**AGENDA FOR THE
MARINA COMMITTEE**

Date and Time of Meeting: March 7, 2022 at 5:00 p.m.

Location: County Building

- 1) Call Meeting to Order
- 2) Persons Wishing to Address the Committee/Public Comment (If requesting action, also list below in section three).
 - a.
 - b.
- 3) Items for Discussion and Possible Action
 - a. Approve February 7, 2022 minutes
 - b. Approve claims
 - c. Approve contractor to do barge work - \$28,000
 - d. Purchasing additional floats - \$10,000
 - e. Breakwater options for gas dock
 - f. Repair light fixtures in bathrooms by the ramp
 - g.
- 4) Closed Session
 - a.
- 5) Items for Discussion Only (No Action Requested)
 - a.
 - b.
 - c.
- 6) Motion to adjourn.

Posted: March 2, 2022 at 4:20 p.m.

By: Dee Dee Rentmeister

PROJECT LOCATION
CLINTON LAKE

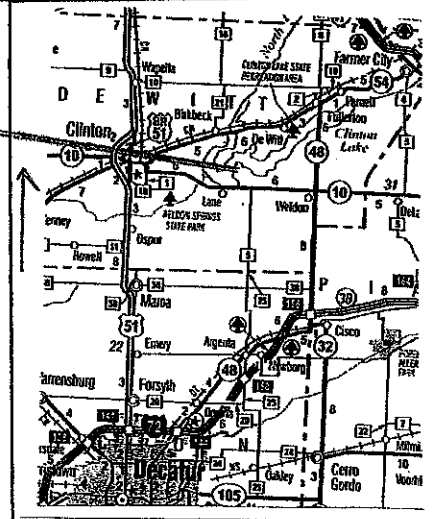

VICINITY MAP



NEW FLOATING BOAT
DOCK FOR BOSTON WHALER

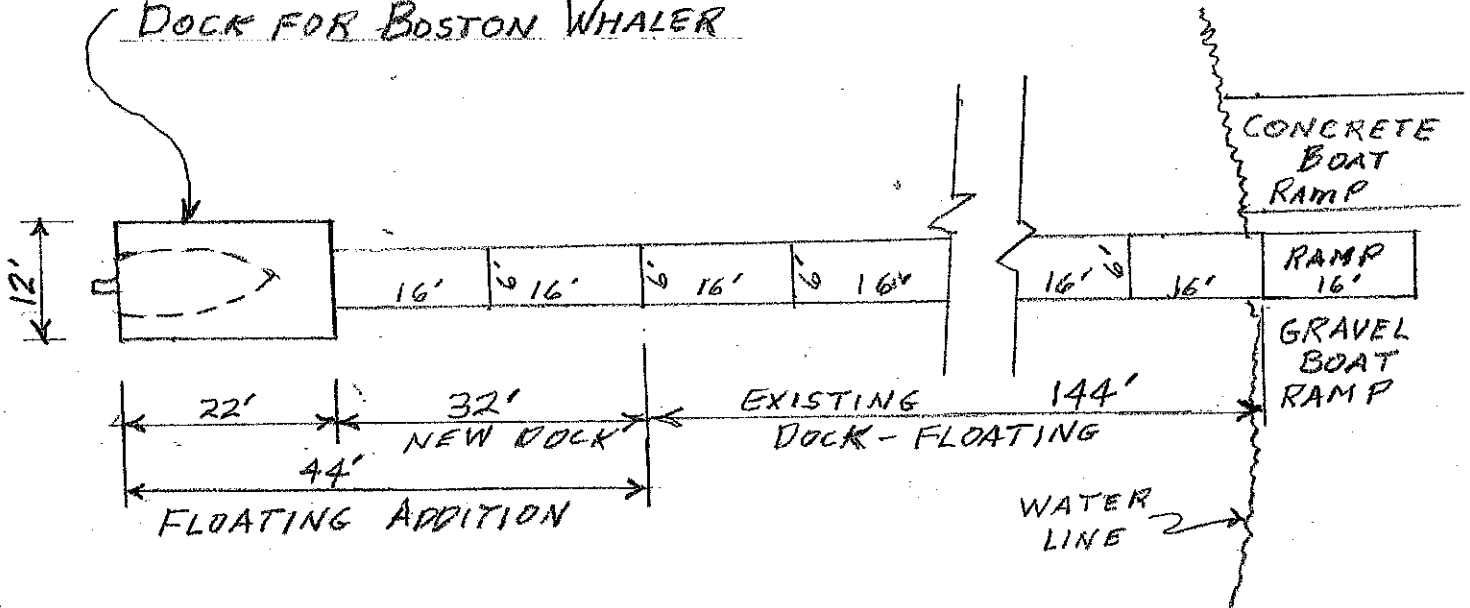

LIST OF ADJACENT PROPERTY OWNERS

| NO. | NAME | ADDRESS |
|-----|---------------------------|--|
| 1. | CLINTON LAKE MARINA | 6599 SAILBOAT ROAD WELDON, IL 61882 |
| 2. | AMERGEN ENERGY COMPANY | 471 1675 E. CLINTON IL 61727 |
| 3. | | |
| 4. | | |

PROJECT DESCRIPTION

ADD 32' x 6' DOCK &
FLOATING BOAT DOCK

LOCATION:

CLINTON LAKE MARINA
SAILBOAT DOCK 3/5



1 Quebec Drive, Seguin, Ontario P2A 0B2
1.888.480.3777 F 705.378.5068 T 705.378.2453
www.kropfindustrial.com info@kropfindustrial.com

March 10, 2022

Contract for Floating Breakwater System – Barefoot Cove Marina

Between:

The Purchaser

DeWitt County Board
201 W. Washington St
Clinton, IL
61727

And the Seller:

Kropf Industrial Inc.
1 Quebec Dr
Seguin, ON
P2A 0B2

Kropf Industrial agrees to supply and deliver a new floating breakwater system as per the attached layout drawing entitled "Proposal B Feb 16-22", with the following specifications:

1. Layout Details – Proposal B

General Layout: "Proposal B Feb 16-22"

General Design as per Typical Drawing: "12' x 50' Low No Deck Double L BW"

Six sections of 12' wide Double L Breakwater

Total overall length to be 310'

2. Design Criteria

Unit to provide estimated wave attenuation as per the following details:

Condition 1: 12" wave with a 2 second period – 80% attenuation

Condition 2: 18" wave with a 2.5 second period – 55% attenuation

Unit is not designed to provide any significant wave attenuation for waves with periods exceeding 3 seconds.

Unit to resist typical static ice conditions.

3. Permits

Applying for and maintaining permits are the sole responsibility of the purchaser. Delays resulting from not having the correct permits on hand will result in an extension of the completion date.

The Seller will provide all reasonable support in order to obtain permits, including supplying drawings and other specifications for use in permit applications.

4. Workmanship and Supervision

All work is to be carried out in a professional matter, using materials and methods suitable for the installed location and intended usage, and conforming to industry standards and best practices as per the details of this contract.

5. Seller's Insurance

Kropf Industrial Inc. is to maintain for the duration of the project insurance as per the following requirements:

1. WSIB coverage as required by the Province of Ontario for all personnel involved on this project.
2. Public & General Liability Insurance, covering bodily injury and/or property damage with limits of liability not less than \$2,000,000.00 for each person or claim and \$2,000,000.00 for each accident or disaster in the aggregate;
3. Property Damage Insurance, with limits of liability not less than \$2,000,000.00 for each accident and \$2,000,000.00 per occurrence
4. Automobile Liability Insurance covering bodily injuries with limits of not less than \$2,000,000.00 per person, and \$2,000,000.00 per occurrence, and coverage for property damage of not less than \$2,000,000.00 per occurrence, for any accident arising out of or resulting from the operation, maintenance, or use by Contractor, its agents, or employees, of any owned, non-owned, or hired automotive equipment.
5. Environmental Liability Insurance with a limit of not less than \$2,000,000.00 per occurrence.

6. Floatation

- 1/4" x 26" spiral welded steel floatation pipes
- Twin pipes for each breakwater section

7. Framing and sub-structure

- Welded HSS framing between pipes with saddle-plating and gussets
- 3/16" steel plate baffles below both pipes in L-shape
 - o Internal 3/16" plate welded gussets to stiffen baffle

- 3" x 3" x 3/16" angle iron braces between bottom of baffles
- Robust and silent heavy duty hinge connection between main breakwater sections
 - o Tapered pins and ears with internal rubber bushings
 - o Pins to be 2" diameter hot dip galvanized steel pins
 - o Hinge ears to be minimum 1" thick
- Outside ends of units to be equipped with hinge points for future expansion if required

8. Corrosion Protection

- All steel surfaces sandblasted to near-white metal
- Amerlock 2 advanced epoxy coating to minimum 12.0 mils DFT
- Sandblasting performed in covered area
- Coating applied indoors in climate-controlled paint booth
- Coating quality inspected minimum of three times prior to installation

9. Decking and Bollards

- 4" x 4" pressure-treated stringers bolted to steel subframe
- Galvanized steel bar grating mounted to stringers for maintenance and service access
- Single 2" x 8" pressure-treated skirt board bolted to steel sub-frame

10. Anchoring

- Steel anchor pockets welded to side of float pipes
- Bottom of pockets to have beveled reinforcement plate to prevent chain abrasion
- Horizontal key slot at top of pocket
- ½" Gr 40 HDG anchor chain (2,500' included)
- 3 ton concrete anchors NOT included
 - o Shackles for securing chain to anchors not included
- Portable chain adjustment winch included

11. Delivery

- Breakwater sections delivered complete with decking
- Delivered with flat-bed trucks (3 loads)
 - o Trucks shall not necessarily be arriving all on the same day
- Customer to provide crane for unloading trucks as required

12. Assembly and Installation

- Launch, assembly, and installation not included
- Kropf to provide installation instructions
- Kropf to provide installation supervisor for three days on site plus travel

13. Service and Inspection Requirements

- Loosen chains in Fall prior to ice forming
- Adjust chains in Spring to normal tension
- Visual inspection once annually of entire system
- Hinge pins between sections should be inspected twice per season to ensure retaining bolts are in place and properly torqued
- Underwater inspection every five years of chains and anchor blocks

14. Warranty

- 5 year structural warranty on design, workmanship, and materials
- No warranty in the case of damage from moving ice
- Warranty does not apply to estimated wave attenuation and does not cover damage resulting from transmitted waves

15. Contract Price and Change Orders

The total contract price for this project shall be:

| | |
|---|--------------------------------|
| Supply and Deliver Breakwaters: | \$306,000.00 USD |
| Install supervisor (3 days plus travel): | \$ 2,895.00 USD |
| <u>TOTAL CONTRACT PRICE:</u> | <u>\$308,895.00 USD</u> |

The total contract price includes all materials, resources, personnel, etc required to execute the project as per the conditions and specifications listed in this contract.

Changes to the Contract Price must be authorized by a Change Order, signed by an authorized representative of the Purchaser.

16. Payment Schedule

Kropf Industrial is proposing the following payment schedule, based on the extended timeline of the project:

| | | |
|------------|------------------|--|
| Deposit: | \$ 92,668.50 USD | Due Immediately as Order Confirmation |
| Payment 1: | \$185,337.00 USD | Due prior to shipment of product |
| Payment 2: | \$ 27,994.50 USD | Due 45 days after completion of delivery |
| Payment 3: | \$ 2,895.00 USD | Due upon completion of install supervision |

When an invoice is received, the County has seven calendar days to provide Kropf Industrial with a written notice disputing the invoice amount or the work covered by the invoice. If no notice is submitted within this time frame, the invoice shall be deemed to have been accepted, and payment shall be made promptly within thirty days of the invoice date.

17. Completion Date and Progress Updates

Delivery of all breakwater sections is to be completed on or before July 27, 2022.

Kropf Industrial shall provide regular updates regarding the progress and delivery schedule of the sections beginning as soon as required by the County and the County's installation contractor. Updates shall be provided no less than bi-weekly beginning June 1, 2022.

The completion date can be extended for any reason by mutual agreement between the Purchaser and Seller. Changes to the scope of work made either at the request of the County or in response to unforeseen conditions will result in an appropriate extension to the completion date.

Subject to the above conditions, Kropf Industrial will make every reasonable effort to complete the project as early as possible, regardless of what conditions or delays are encountered.

18. Notes

1. Seller shall not be liable for failure to deliver, or delays in delivery caused by fires, inability to obtain material or shipping space, breakdowns, delays of carriers or suppliers, Governmental acts and regulations, and other causes beyond the reasonable control of the seller.
2. In order for this contract to be valid it must be signed and returned with deposit no later than March 31, 2022 (no exceptions without written approval from Kropf Industrial Inc.).
3. No work will be scheduled until deposit is received regardless of signed contract being returned. If the deposit is not received by March 31, 2022, the project delivery may be rescheduled to next available manufacturing and installation dates.
4. Any bank fees incurred for a deposit or payment of an invoice are the sole responsibility of the purchaser.

If the details, terms, pricing, and the attached drawings are acceptable, we would ask that you sign below in agreement, and return by courier to Kropf Industrial, along with your deposit **made payable to Kropf Industrial Inc** as order confirmation. Please also initial the attached drawing to avoid any misunderstandings.

I trust this is acceptable, and we look forward to your response. Please do not hesitate to call if you have any questions.

SIGNED AND ACCEPTED on Behalf of DeWitt County Board,

Signature

Date

Print Name - *I have the authority to bind the entity noted above

SIGNED AND ACCEPTED on Behalf of KROPF INDUSTRIAL INC.,

Jordan Kropf
Kropf Industrial Inc

Date

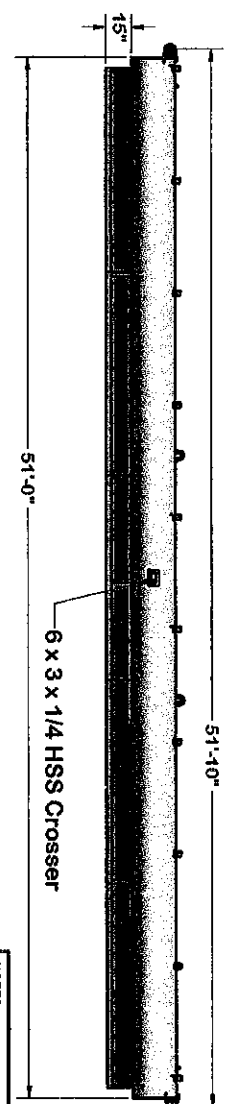
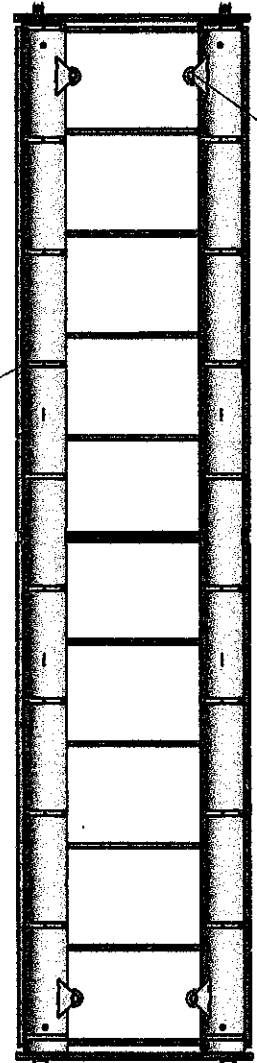
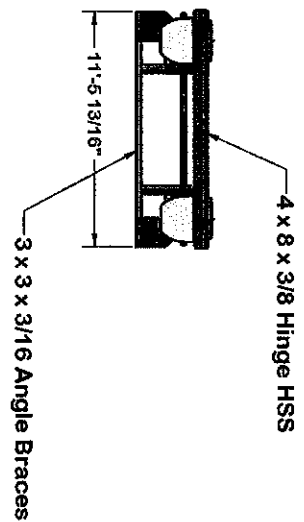
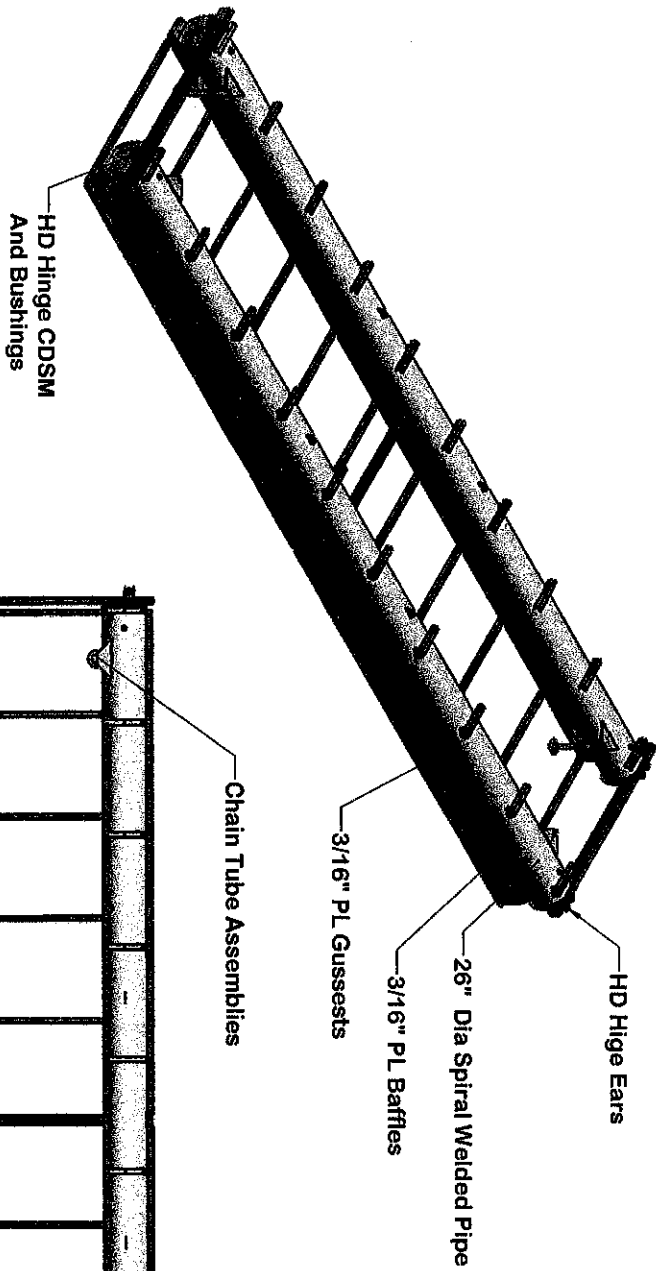

NOTES:
 1. WELDING: CSA W47 1 ALUMINUM - CSA W47 2 ALUMINUM - CSA W47 3 STEEL
 2. ALL ALUMINUM STRUCTURAL MEMBERS ARE B081-115 EQUIVALENT TO THICKNESS OF MEMBERS BEING JOINED.
 3. UNLESS OTHERWISE SPECIFIED 90M IS STEEL.
 4. SPECIFIED LOADS.

| | | | | | | | |
|--|--|--|--|---------------------------------|--|------------------------|--|
| NOTES | | PART NUMBER | | DRAWINGS | | JOB NUMBER | |
| 13185 Lbs Decked 19" Deck Height | | 12 x 50 Low No Deck Double L BW | | 12 x 50 Low No Deck Double L BW | | 1 | |
| <p>A TITLE _____</p> <p>B/C SCALE _____</p> <p>A DETAIL NUMBER - WHERE DETAIL B SHEET NUMBER - WHERE DETAIL C SHEET NUMBER - WHERE DETAIL (LOCATED)</p> | | MODEL 12 x 50 Low Dbl L BW | | DRAWN BY: MS | | DRAWN DATE Feb 1-22 | |
| CUSTOMER | | CHECKED BY: | | REVISION DATE: | | SCALE | |
| REV DESCRIPTION: | | REV DESCRIPTION: | | REV DESCRIPTION: | | SHEET NUMBER 1 OF 3 | |
|  | | <p>THIS DRAWING IS THE PROPERTY OF KROPE INDUSTRIES AND IS NOT TO BE COPIED OR REPRODUCED WITHOUT WRITTEN PERMISSION</p> | | | | | |

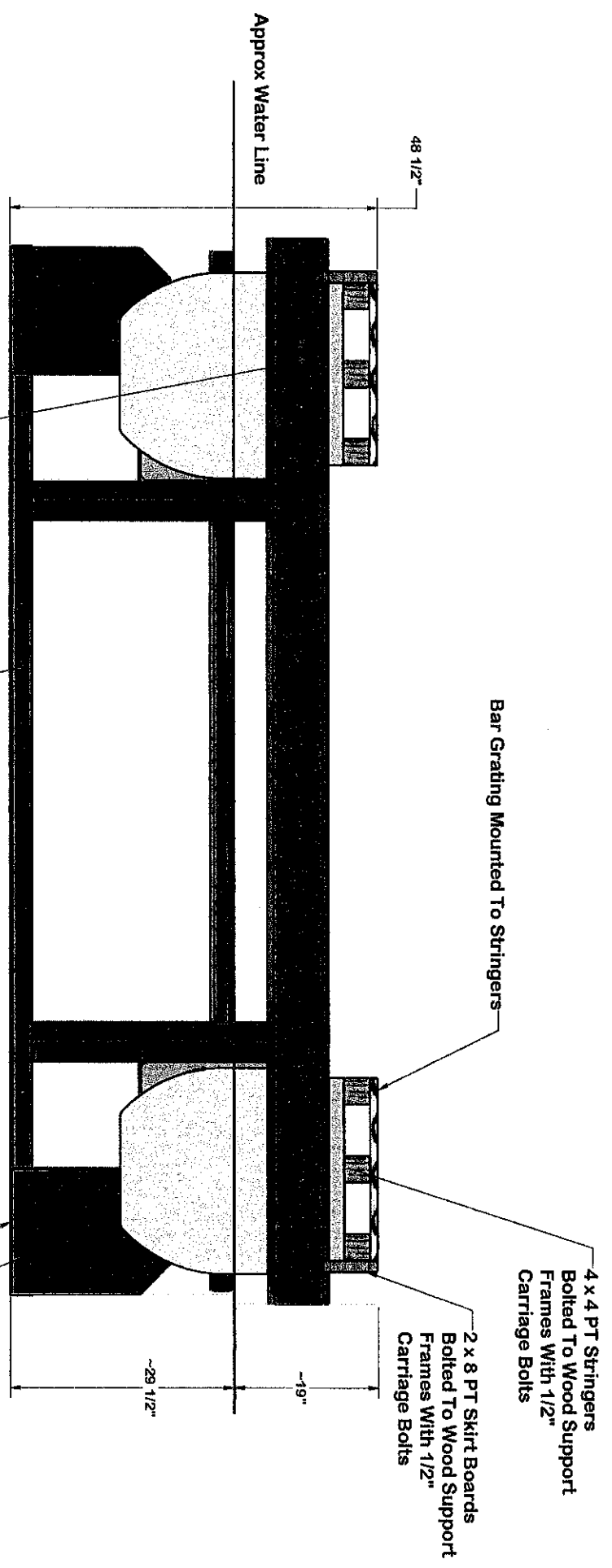

HD Hinges

3 x 3 x 3/16 Angle Braces

3/16" PL Baffle Gussets
3/16" PL Baffle

Bar Grating Mounted To Stringers

4 x 4 PT Stringers
Bolted To Wood Support
Frames With 1/2"
Carriage Bolts

2 x 8 PT Skirt Boards
Bolted To Wood Support
Frames With 1/2"
Carriage Bolts

- NOTES:
1. FINISHING:
STEEL - CSA W47.1
ALUMINUM - CSA W47.2
UNLESS OTHERWISE SHOWN, WELD SIZE SHALL BE
EQUivalent TO THICKNESS OF MEMBERS BEING JOINED.
2. ALL STEEL STRUCTURAL MEMBERS ARE A490.
3. UNLESS OTHERWISE SPECIFIED BOM IS STEEL.
4. SPECIFIED LOADS:

NOTES

PART NUMBER

MODEL
12 x 50 Low Dbl L BW

CUSTOMER

DRAWINGS

12 x 50 Low No Deck Double L BW

DRAWN BY:
MS

CHECKED BY:

REV DESCRIPTION:

DRAWN DATE
Feb 1-22

REVISION DATE:

SCALE

JOB NUMBER

SHEET NUMBER
2
OF
3



THIS DRAWING IS THE PROPERTY OF KROPP INDUSTRIAL AND IS NOT TO BE COPIED OR REPRODUCED WITHOUT WRITTEN PERMISSION



TITLE

SCALE

- A. DETAIL NUMBER - WHERE DETAIL REQUIRED
B. SHEET NUMBER - WHERE DETAIL REQUIRED
C. SHEET NUMBER - WHERE DETAIL LOCATED

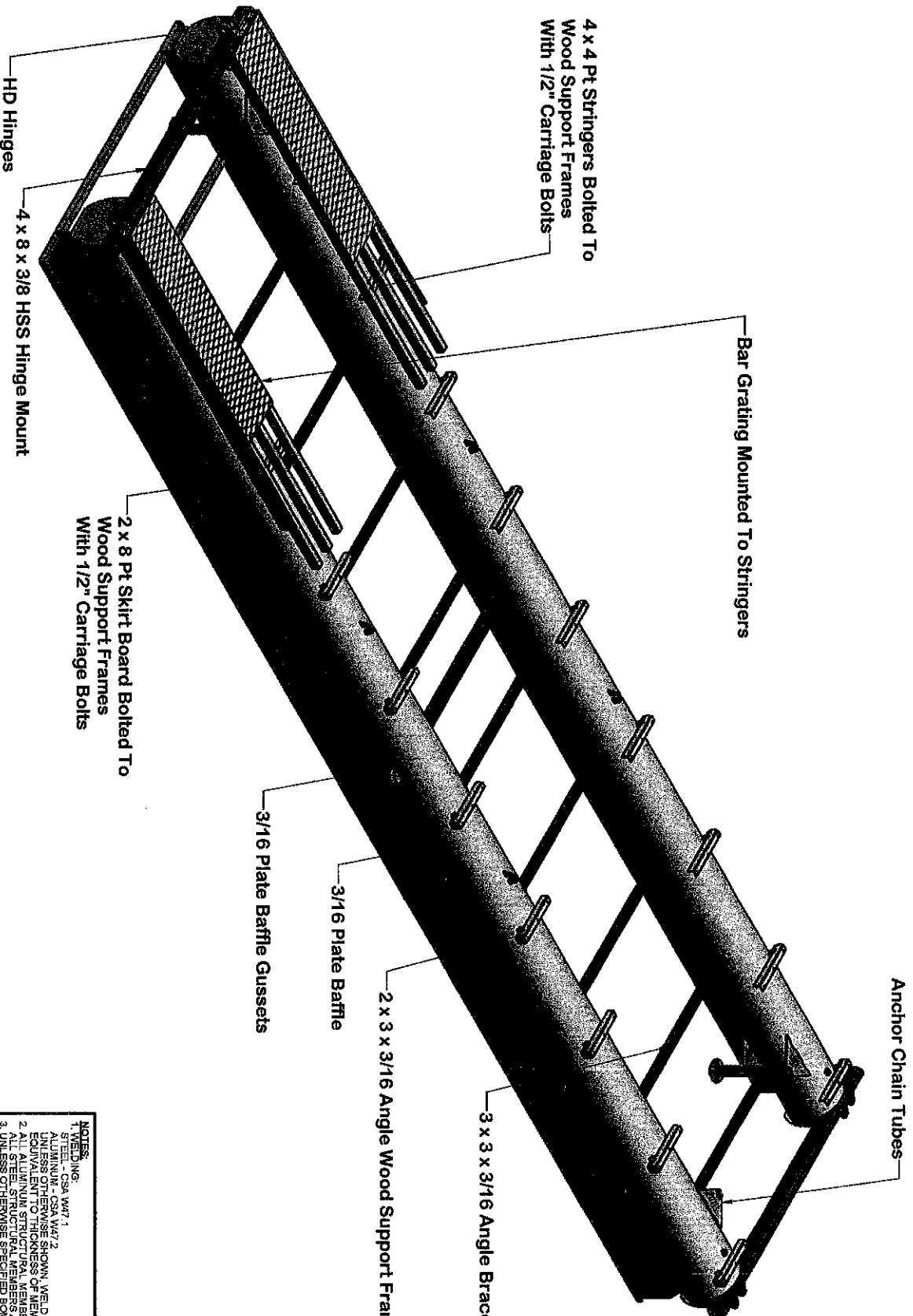

NOTES:
 1. WELDING: STEELING: WWT 1. ALL WELDS TO BE WELDED TO CSA W47.2 UNLESS OTHERWISE SHOWN. WELD SIZE SHALL BE EQUIVALENT TO THICKNESS OF MEMBERS BEING JOINED.
 2. ALL ALUMINUM STRUCTURAL MEMBERS ARE 6061-T6.
 3. ALL STEEL STRUCTURAL MEMBERS ARE A36.
 4. SPECIFIED LOADS: TO BE SPECIFIED FROM 15 STEEL.

NOTES

| | |
|------------|-------------------------------------|
| A | TITLE |
| B/C | SCALE |
| A | DETAIL NUMBER - WHERE DETAIL |
| B | SHEET NUMBER - WHERE DETAIL |
| C | SHEET NUMBER - WHERE DETAIL LOCATED |

| | |
|----------------------|--|
| PART NUMBER | DRAWINGS |
| MODEL | 12 x 50 Low No Deck Double L BW |
| 12 x 50 Low Dbl L BW | DRAWN BY: MS |
| CUSTOMER | CHECKED BY: MS |
| | REV DESCRIPTION: |

| | |
|-------------------|-----------------------|
| DRAWN DATE | REVISION DATE: |
| Feb 1-22 | |
| SCALE | |

KROPE CONDUIT AQUACULTURE
 INDUSTRIAL
 THIS DRAWING IS THE PROPERTY OF KROPE INDUSTRIAL AND IS NOT TO BE COPIED OR REPRODUCED WITHOUT WRITTEN PERMISSION

| | |
|-------------------|---------------------|
| JOB NUMBER | SHEET NUMBER |
| | 3 OF 3 |

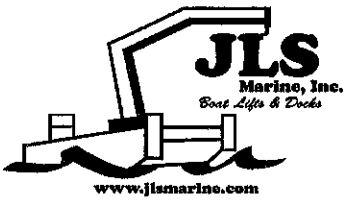

JLS Marine, Inc.
5416 N. Cotton Hill Rd.
Springfield, IL 62703

Date: March 7, 2022
Phone: (217)341-1730

Email:
Cell Phone: 217-306-6576
Home Phone:
Boat:
Lake: Clinton Marina Barefoot Cove
Notes: Dan Matthews Joe Caldwell

County of Dewitt - Illinois
201 West Washington St.
Clinton, IL 61727

| QUANTITY | DESCRIPTION | UNIT PRICE | AMOUNT |
|----------|---|-------------|--------|
| | Bring barge to Clinton to disconnect Dock 7 slips from pavillion/Ga | \$ 5,000.00 | \$ - |
| | Dock portion, float over to shoreline and disassemble so sections | | \$ - |
| | can be removed from water with customer provided excavator and | | \$ - |
| | excavator labor. Use barge to set ramp on Dock 7. Set customer | | \$ - |
| | provided anchor pipe as needed on Dock 7. If time allows, adjust | | \$ - |
| | floatation to better level fingers on Dock 7. | | \$ - |
| | | | \$ - |
| | | | \$ - |
| | JLS Marine is not responsible for hauling our disposal of old mate | | \$ - |
| | | | \$ - |
| | Proposal is based transportation of barge to Clinton and back as i | | \$ - |
| | estimated to take one day with two JLS Marine employees. | | \$ - |
| | | | \$ - |
| | No materials are included in this proposal. Barge and Labor only. | | \$ - |
| | | | \$ - |
| | | | \$ - |
| | | | \$ - |
| | | | \$ - |
| | | | \$ - |
| | | | \$ - |

SUBTOTAL \$ -

Payment Schedule:

50% Down, 50% on Delivery/Installation
20% Restocking Fee for returned Merchandise

SALES TAX \$ -

SHIPPING AND HANDLING \$ -

BARGE and LABOR ONLY \$ 5,000.00

TOTAL \$ 5,000.00

Deposit Amount: Deposit Date:
Check Number: Balance Due:

THANK YOU FOR YOUR BUSINESS

Customer Acceptance

Atchison Electric, Inc.

P.O. Box 222
 1015 W. Jackson
 Sullivan, IL 61951

QUOTATION

Quote Number: 21210
 Quote Date: Sep 13, 2021
 Page: 1

Voice: 217-728-4713
 Fax: 217-728-2384

| |
|---|
| Quoted To: |
| CLINTON MARINA ATTN: DEDE RENTMEISTER 201 W WASHINGTON CLINTON, IL 61727 |

| Customer ID | Good Thru | Payment Terms | Sales Rep |
|-------------|-----------|---------------|-----------|
| CLIMAR | 10/13/21 | Net 30 Days | |

| Quantity | Item | Description | Unit Price | Amount |
|----------|--------|--|--------------|---------------|
| 2.00 | M | MOTION SENSORS | 242.39 | 484.78 |
| 2.00 | N110 | 1/2 X 4 NIPPLE | 1.85 | 3.70 |
| 2.00 | WB165 | 4" OCT 3/4 KO 2 1/2D BOX | 3.62 | 7.24 |
| 8.00 | FLN105 | 1/2" LOCKNUT | 0.20 | 1.60 |
| 4.00 | FBU105 | 1/2" PLASTIC BUSHING | 0.12 | 0.48 |
| 1.00 | M | MISC. MATERIAL | 60.00 | 60.00 |
| 5.00 | L | LABOR/SERVICE | 87.50 | 437.50 |
| | | Installing a motion detector for the lights in the mens and womens bathrooms. This estimate only includes removing photo cell and installing the motion sensors. Bulbs or fixtures to be done by others This quote is to be done with other jobs while on site. We would have to charge travel time if this is an individual job. Thank you. | | |
| | | | Subtotal | 995.30 |
| | | | Sales Tax | |
| | | | TOTAL | 995.30 |